

DIRECTORY:

FITTING POSITIONS SHOWN ARE STANDARD. PLEASE INDICATE WITH DIMENSIONS IF REQUIRED IN A DIFFERENT LOCATION.
TANK SHOWN IS SUITABLE FOR VDO STYLE SENDER (WITH PICKUP / RETURN PIPES IN SENDER UNIT).

ISSUE	DETAILS	DATE
A	TO BE APPROVED FOR MANUFACTURE	

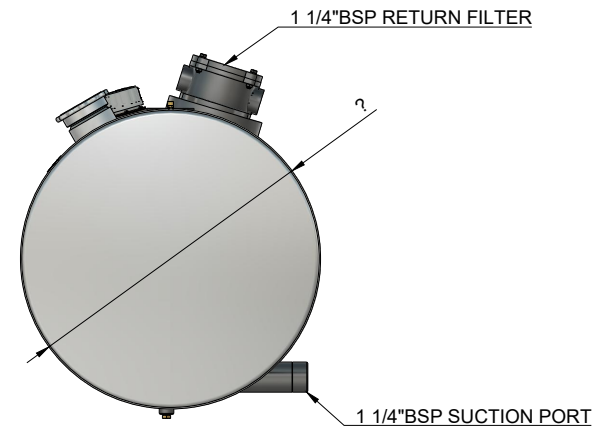
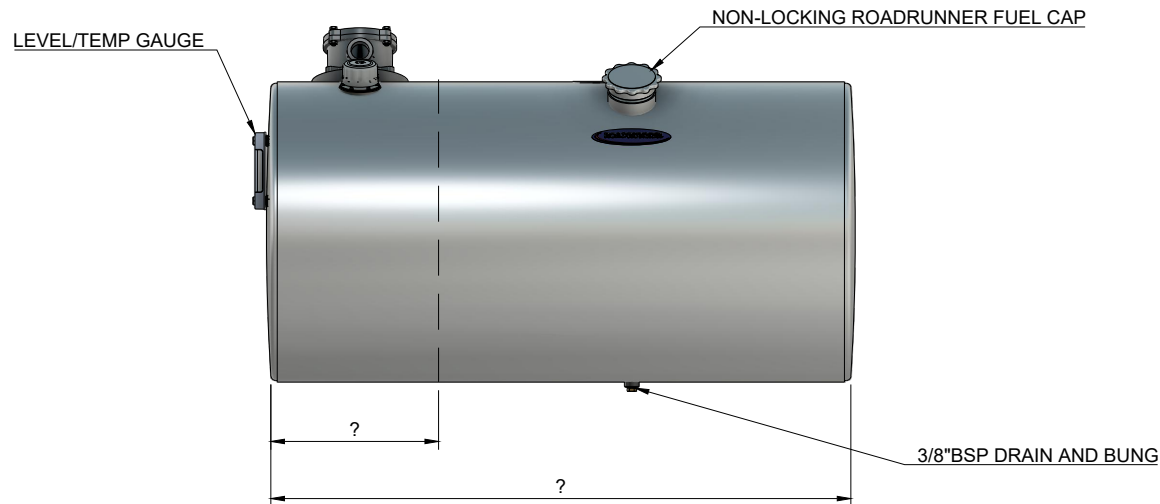
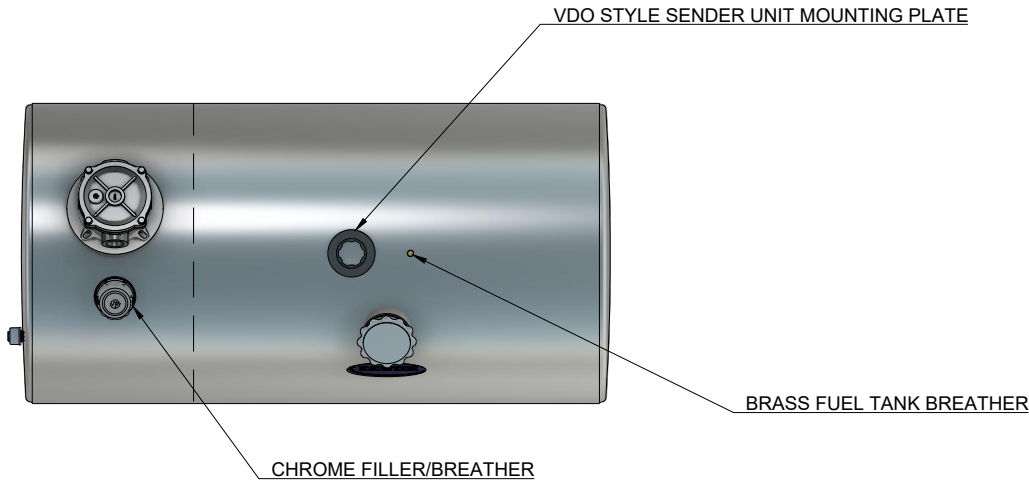

TANK DIAMETER	
Ø 380	
Ø 460	
Ø 570	
Ø 635	
Ø 660	
Ø 710	

THIS DRAWING AND/OR ELECTRONIC MEDIA CONTAINING THIS DRAWING REMAIN THE PROPERTY OF ROADRUNNER MANUFACTURING LTD. IT MAY NOT BE COPIED OR USED IN ANY UNORTHERRISED MANNER

ROADRUNNER
ROADRUNNER MANUFACTURING (NZ) LIMITED



CLIENT:

TITLE: Round Combo Tank Specs - VDO Type Sender

DATE:

SCALE:
1:16

DRAWN BY:
Steve Tunncliffe

PRODUCT CODE:

JOB NUMBER

SHEET:

1/1

ISSUE: